



## Single Channel Programmable Digital Transceiver

*WaveWalker PCI* adds a high performance software defined radio capability to any computer with a PCI backplane. The product combines the flexibility, performance, and precision of advanced digital transceiver chips with a modern analog IF front-end to provide a complete solution in the footprint of a single module. The industry standard PCI interface simplifies programming and eases the transition from a desktop development environment to an embedded target platform. A single module contains independent receive and transmit channels that share a common command and data interface to the host processor.

The receiver accepts an analog IF input through an SMB connector located on the front panel. The signal is routed through a digitally controlled attenuator and buffer amplifier immediately preceding the analog anti-alias filter. A second amplifier stage boosts the signal to match the input range of the A/D converter. The second IF produced by the A/D converter is passed to a digital downconverter that tunes to the signal of interest and performs amplitude adjustment based on gain control settings. The complex data samples produced by the downconverter are stored in a FIFO for extraction by the host.

The transmitter data flow begins at the host interface with the transfer of data samples from the processor to a FIFO located on the module. The samples are rate buffered out of the FIFO to match the clock frequency at the input of the digital upconverter. The upconverter performs a digital filter operation followed by a frequency translation to establish a first IF compatible with the input to the D/A converter. The output of the D/A converter passes through an analog interpolation filter and mixer for upconversion to the final IF. The output signal is supplied through an SMB coaxial connector on the front panel after a final stage of signal conditioning.

- ▲ *Industry Standard PCI Form Factor*
- ▲ *Software Defined Radio Building Block*
- ▲ *70 MHz IF / 12.5 MHz Analog Bandwidth*
- ▲ *1.25 MHz Digital Receiver Bandwidth*
- ▲ *1.25 MHz Digital Transmitter Bandwidth*
- ▲ *Up to 90 dB Linear Dynamic Range*
- ▲ *-20 dBm Max Input / +5 dBm Input TOI*
- ▲ *Software Programmable Sample Rates*
- ▲ *Simple Memory-Mapped Host Interface*
- ▲ *Front Panel Control for Synchronization*
- ▲ *Includes Windows 95/98/NT/2000 Drivers*
- ▲ *Includes Waveformer Configuration Tool*

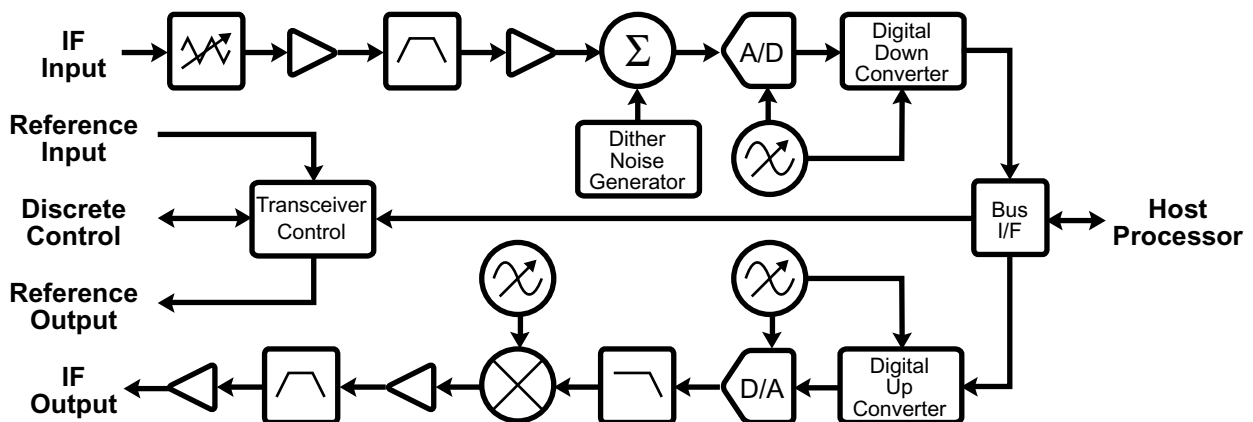

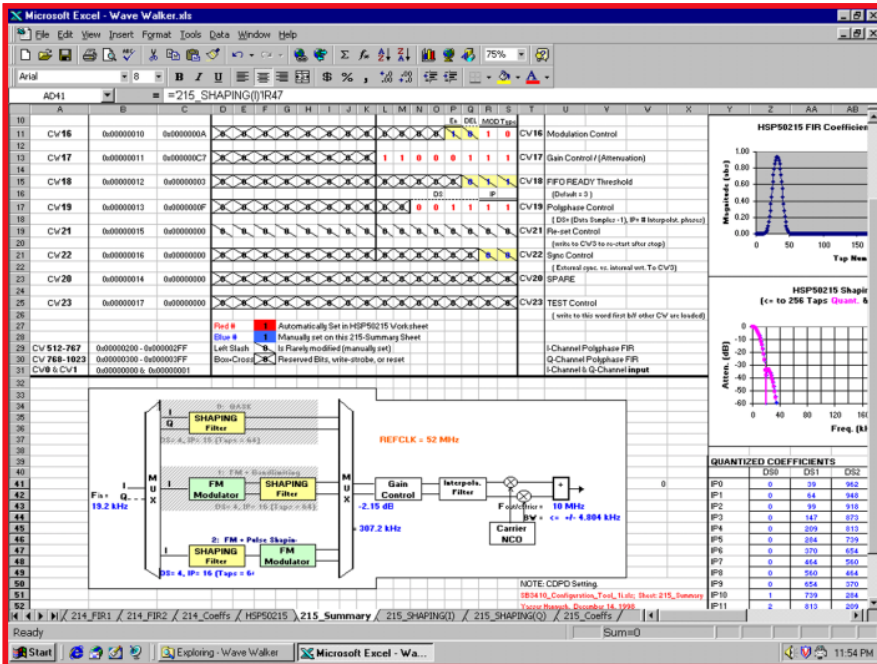

**The Waveformer configuration tool simplifies transceiver programming.**

The *WaveWalker PCI* occupies 16k of PCI memory space accessed from a single base address register. The host processor has direct access to all control registers, including the receiver input attenuator level, dither noise power level, receiver sample rate, downconverter (HSP50214) configuration space, transmitter sample rate, upconverter (HSP50215) configuration space, local command/status, and transceiver data flow control. The bus interface includes an interrupt to alert the host of an error condition or data service request.

*WaveWalker PCI* programming is simplified by the *Waveformer* configuration tool that automates the process of computing register values based on the desired performance characteristics of the transceiver. The user enters configuration information through a series of guided spreadsheets that describe the purpose of each control register, setting options, and default values. The spreadsheets also perform error checking to eliminate configuration conflicts and graphically display key performance parameters in architecture block diagrams and frequency response plots. The configuration tool generates a file containing the complete memory map that can be easily uploaded from the host.

### Typical Applications

- ▲ Multi-Mode Base Stations (GSM, AMPS, IS54, IS95)
- ▲ Beamforming / TDOA (Smart Antenna, E911)
- ▲ Military Communications (AM, FM, FSK, PSK, DAMA)
- ▲ Multi-Mode Wireless Local Loop
- ▲ Software Defined Radio
- ▲ Satellite Communications

### Specification Summary

#### ▲ Receiver

- 70 MHz Analog IF Input
- 12.5 MHz Analog Input Bandwidth
- 20 dBm Input Power (Full Scale)
- +5 dBm 3<sup>rd</sup> Order Intercept Point
- 40 dB Variable Analog Gain Control
- 12-bit, 53 to 60 MSPS A/D
- Harris HSP50214 Downconverter
- 1.25 MHz Max Digital Bandwidth
- Digital Automatic Gain Control
- 90 dB Linear Dynamic Range (30kHz)

#### ▲ Transmitter

- 5.5 MSPS Max Complex Input
- Harris HSP50215 Upconverter
- 3.25 MHz Max Digital Bandwidth
- 14-bit, 45 to 52 MSPS D/A
- 70 MHz Analog IF Output
- 12.5 MHz Analog Output Bandwidth
- 15 dBm Output Power (Full Scale)
- +25 dBm 3<sup>rd</sup> Order Intercept Point
- 80 dB Spur-Free Dynamic Range

#### ▲ Board

- PCI Short Compliant Physical
- 32-bit, 33 MHz PCI 2.1 Bus
- SMB Coaxial Analog I/O
- 12.80 MHz 3 ppm Local Reference
- 5 to 25 MHz Reference Input

#### ▲ Options

- Baseband Analog I/O
- PCI, CPCI, VME Solutions Available
- Customization Available by Request

**For further information, contact:**

**Red River**

797 North Grove Rd, Suite 101  
 Richardson, TX 75081  
 Phone: (972) 671-9570  
 Fax: (972) 671-9572  
 www.red-river.com