



Highlights

- >> Hot-Swap N+1 Load Sharing
- >> DIN Input/Output Connector
- >> Protection Features:
 - Overvoltage
 - Short Circuit-All Outputs
 - Overtemperature Protection
- >> Status LEDs: Fault, Input OK
- >> Status Output Signals: (DEG#), (FAL#)
- >> Main Output Remote Sense (+3.3V, +5V)
- >> Built-In EMI Filter
- >> Eurorack-Compatible Module
- >> Front Drawer-Style Handle

The ZT 6311 Hot-Swap DC Power Supply is a highly reliable modular package designed for DC power input systems. This highly dense, redundant supply is ideally suited for telecommunications, industrial automation and a variety of embedded computer applications utilizing the CompactPCI® 3U form factor.

The input voltage range is 36 to 72VDT. Four outputs are capable of providing a total of 150W for +3.3VDT, +5VDT and ± 12 VDT with independent output regulation. The low-cost unit meets the electrical and mechanical requirements of the PICMG® specification for CompactPCI systems. It uses a DIN power connector to provide efficient, effective DC connectivity and is UL, CSA, IEC, TUV and CE certified.

The ZT 6301 150-Watt Hot-Swap AC Power Supply is available as an AC alternative.

Design Elements

Operation

The ZT 6311 150W power supply utilizes switching technology to achieve its small size and large power output. An EMI-filtered input automatically accepts DC input voltages from 36 to 72 volts. Optionally, two or more power supplies can be used to implement an N+1, load sharing, fault-tolerant system.

Load Sharing and N+1 Redundancy

Two power supplies can share the same input source. These two supplies each supply approximately 50 percent of the total system power during normal operation, although either is capable of powering the entire system in the event that the other should fail (with a 150W load). This feature increases overall system reliability by sharing the load responsibilities. Additional power supplies may be used to implement true N+1 load sharing (i.e., a 300W system requires two power supplies, plus a third for redundancy).

Hot-Swap and Fault Tolerance

The ZT 6311 power supply can be inserted or removed from the system without disturbing operation or reducing the reliability of any associated devices. Likewise, a failed power supply will not disturb the operation of the system if a redundant power supply is operating in the system.

Status LEDs

Two status LED indicators are visible from the front of the power supply. The green "INPUT" LED indicates that the input voltage is present. The amber "FAULT" LED indicates a failed power supply or input source.

Remote Sense

A common, remote sense on the +3.3V and +5V power supply outputs will detect the voltage at a load remote from the power supply, compensating for connector, backplane and wiring voltage drops. The 3S+ and 5S+ signals should be connected to the proper load.

ZT 6311

150-Watt Hot-Swap DC Power Supply

Inhibit/Enable Inputs

The INH# input signal on the rear connector will turn off the outputs when grounded. The enable (EN#) input must always be connected to ground.

System Notification

Two fault outputs are available on the rear connector for system notification. One output (DEG#) is an open collector, low true signal that indicates the internal temperature is approaching 90 C. If action does not reverse the internal temperature rise, at 100 C the supply will shut off the outputs. The second output (FAL#) is an open collector, low true signal that indicates when the supply has a problem, or the input voltage has been removed.

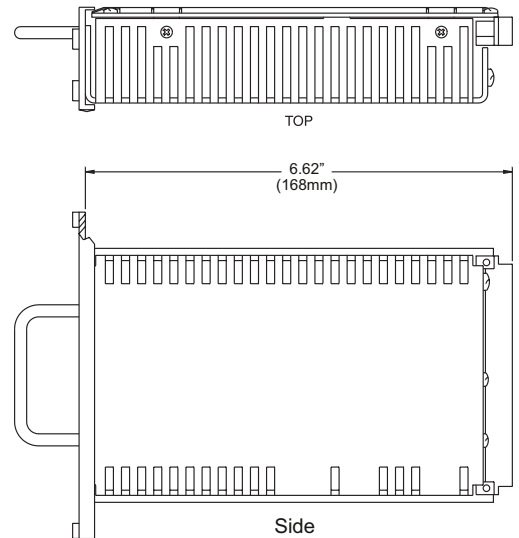

All Dimensions are approximate

Figure 1. Close Up Views

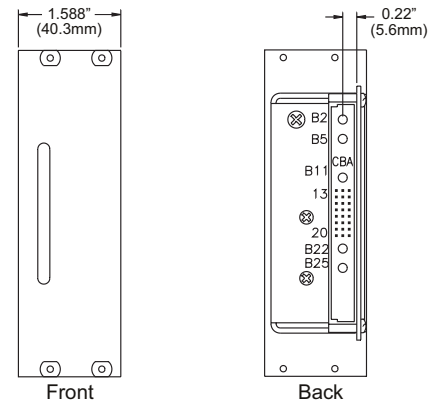

Contact Information

Performance Technologies

205 Indigo Creek Dr.
Rochester, NY 14626
Tel: 585-256-0200
Fax: 585-256-0791
E-mail: sales@pt.com

www.pt.com

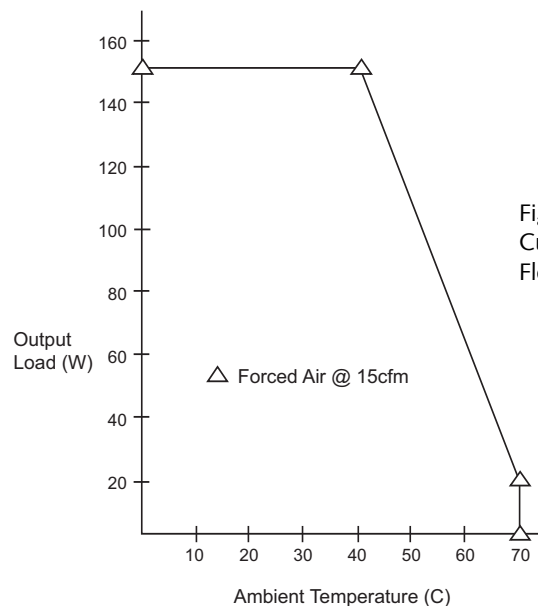
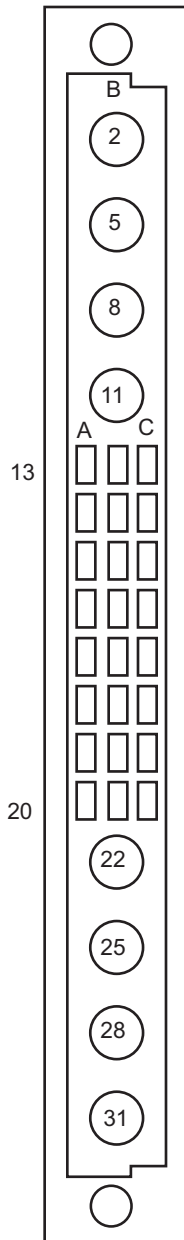

Figure 2. Output Derating Curves For Various Air Flows

ZT 6311

150-Watt Hot-Swap DC Power Supply



Pin # (1)	Staging (2)	Mnemonic	Description
Column A			
A13	EL	SP	Spare (do not connect)
A14	EL	INH#	Inhibit Signal
A15	EL	ISH	Current Share Signal
A16	EL	S-	Sense -
A17	EL	5S+	5V Sense +
A18	EL	3.3S+	+3.3V Sense
A19	EL	+12V	+12 VDC
A20	EL	-12V	-12 VDC
Column B			
B2	-	-	No Pin Loaded
B5	-	-	No Pin Loaded
B8	-	-	No Pin Loaded
B11	EL	CG ⁽³⁾	Chassis Ground
B13-18	SL	3.3V	+3.3 VDC
B19	SL	+12V	+12 VDC
B20	SL	-12V	-12 VDC
B22	EL	5V	+5 VDC
B25	EL	GND	Ground
B28	SL	+DC	+DC Input
B31	SL	-DC	- DC Input
Column C			
C13	SL	EN#	Enable Signal
C14	SL	DEG#	Temp. Warning Signal
C15	SL	FAL#	Supply Fail Signal
C16-18	SL	3.3V	+3.3 VDC
C19	SL	+12V	+12 VDC
C20	SL	-12V	-12 VDC

Figure 3. Pin Numbers

Figure 4. Mating Connector (Top view)

Pin numbers illustrated are the pin view of the female mating connector. A mating connector is ERNI part #914374; AMP #148370-1 or #97-7200-016.

Notes:

- (1) Mating pin numbers on power supply connector.
- (2) EL is an Extra Length pin. SL is a Standard Length pin.
- (3) CG must be connected to earth ground.

Contact Information

Performance Technologies

205 Indigo Creek Dr.
 Rochester, NY 14626
 Tel: 585-256-0200
 Fax: 585-256-0791
 E-mail: sales@pt.com

Ordering Information

>> To discuss your specific requirements and/or pricing, please contact sales@pt.com.

Custom configuration options may be available.

Contact Information

Performance Technologies

205 Indigo Creek Dr.
Rochester, NY 14626
Tel: 585-256-0200
Fax: 585-256-0791
E-mail: sales@pt.com

www.pt.com

Specification

The ZT 6311 is compliant with the following specification:

- CompactPCI Core Specification, PICMG 2.0, R2.1

Electrical

- Input voltage range: 36-72VDT
- Input filter type: Common and differential mode

Environmental

- Operating Temperature: 0 to 70 C
- Storage temperature: -40 to +85 C
- Non-condensing relative humidity: Less than 95% at 40 C

Input Current

- Maximum continuous: 230W
- Cold start, surge maximum: 10A (typically 110% of the static source current, lasting <20ms)

Output Specifications

- Total voltage accuracy (load, cross and line regulation across temperature):

+3.3V* @	20A ±2%
+5V @	25A (2A minimum)* ±2%
+12V @	5.5A ±2%
-12V @	0.5A ±4%

* Combined current not to exceed 25A.

- Total output power (max. continuous @ 35 C with 15 CFM): 150W

Ripple and Noise

Measured at full load with 20MHz bandwidth and 22 µF capacitor at load, or with 50mV, whichever is greater:

+3.3V	<1.0% P-P
+5V	<1.0% P-P
+12V	<1.0% P-P
-12V	<1.0% P-P

- Short circuit protection: Auto recovery
- Overvoltage protection (+3.3V, +5V): 135% maximum

General Specifications

- Efficiency: >69% at 20% to 80% max. load

Environmental Specifications

- Supports overtemp shutdown
- Cooling requirement at sea level: Derate output load by 15% per 6,000 feet (See figure 2)
- Weight: 2.48 lbs (1.12 kg)

Reliability

- MTBF: 450,000 hours (MIL-HDBK-217E)
- MTTR: One minute (based on module replacement)

Regulatory Compliance

Designed for NEBS/ETSI

CE Certification

The ZT 6311 meets intent of Directive 89/336/EEC for Electromagnetic Compatibility & Low-Voltage Directive 73/23/EEC for Product Safety. Compliance was demonstrated to the following specifications as listed in the Official Journal of the European Communities:

Safety

- UL/cUL 60950 Safety for Information Technology Equipment
- EN/IEC 60950 Safety for Information Technology Equipment
- CB Report Scheme CB Certificate and Report

Emissions Test Regulations

- FCC Part 15, Subpart B
- EN 55022
- CISPR 22
- Bellcore GR-1089

EN 50081-1 Emissions

- GR-1089-CORE Sections 2 and 3
- EN 55022 Class A Radiated
- EN 55022 Power Line Conducted Emissions
- EN 61000-3-2 Power Line Harmonic Emissions
- EN 61000-3-3 Power line Fluctuation and Flicker

EN 55024 Immunity

- GR-1089-CORE Sections 2 and 3
- EN 61000 4-2 Electro-static Discharge (ESD)
- EN 61000 4-3 Radiated Susceptibility
- EN 61000 4-4 Electrical Fast Transient Burst
- EN 61000 4-5 Power Line Surge
- EN 61000 4-6 Frequency Magnetic Fields
- EN 61000 4-11 Voltage Dips, Variations & Short Interruptions